



## AD-115ES

MAXIMUM CAPACITY (DRY WEIGHT)		115 lb	<b>52.16 kg</b>	
TUMBLER DIAMETER		42"	<b>106.68 cm</b>	
TUMBLER DEPTH		41-1/4"	<b>104.78 cm</b>	
TUMBLER VOLUME		33.10 cu ft	<b>937.29 L</b>	
TUMBLER/DRIVE MOTOR		3/4 hp	<b>0.56 kW</b>	
BLOWER/FAN MOTOR		3 hp	<b>2.24 kW</b>	
DOOR OPENING (DIAMETER)		31-3/8"	<b>79.69 cm</b>	
DOOR SILL HEIGHT		27-1/2"	<b>69.85 cm</b>	
WATER CONNECTION		3/4"-11.5 NH (North America)		
		3/4" B.S.P.T. (Outside North America)		
DRYERS PER 20'/40' CONTAINER		4 / 8		
DRYERS PER 48'/53' TRUCK		9 / 10		
<b>Gas</b>	VOLTAGE AVAILABLE		208-575V 3ø 3,4w 50/60 Hz	
	APPROXIMATE NET WEIGHT		1,260 lb <b>571.53 kg</b>	
	APPROXIMATE SHIPPING WEIGHT		1,400 lb <b>635.03 kg</b>	
	AIRFLOW	60 Hz	2,100 cfm	<b>59.47 cmm</b>
		50 Hz	1,750 cfm	<b>49.55 cmm</b>
	HEAT INPUT		343,000 Btu/hr	<b>86,435 kcal/hr</b>
	EXHAUST CONNECTION (DIAMETER)		14"	<b>35.56 cm</b>
	COMPRESSED AIR CONNECTION		N / A	
	COMPRESSED AIR VOLUME		N / A	
INLET PIPE CONNECTION		1" F.N.P.T.		
		1" F.B.S.P.T. (CE and Australia Only)		
<b>Electric</b>	VOLTAGE AVAILABLE		208-575V 3ø 3,4w 50/60 Hz	
	APPROXIMATE NET WEIGHT		1,260 lb <b>571.53 kg</b>	
	APPROXIMATE SHIPPING WEIGHT		1,400 lb <b>635.03 kg</b>	
	AIRFLOW	60 Hz	2,100 cfm	<b>59.47 cmm</b>
		50 Hz	1,750 cfm	<b>49.55 cmm</b>
	EXHAUST CONNECTION (DIAMETER)		14"	<b>35.56 cm</b>
	COMPRESSED AIR CONNECTION		N / A	
	COMPRESSED AIR VOLUME		N / A	
	OVEN SIZE			
		kW	Btu/hr	<b>kcal/hr</b>
	60	204,700	<b>51,600</b>	
	72	245,700	<b>61,900</b>	
<b>Steam</b>	VOLTAGE AVAILABLE		208-575V 3ø 3,4w 50/60 Hz	
	APPROXIMATE NET WEIGHT		1,555 lb <b>705.34 kg</b>	
	APPROXIMATE SHIPPING WEIGHT		1,695 lb <b>768.84 kg</b>	
	AIRFLOW	60 Hz	2,100 cfm	<b>59.47 cmm</b>
		50 Hz	1,750 cfm	<b>49.55 cmm</b>
	STEAM CONSUMPTION		375 lb/hr	<b>170.10 kg/hr</b>
	OPERATING STEAM PRESSURE		125 psi max	<b>8.62 bar</b>
	EXHAUST CONNECTION (DIAMETER)		14"	<b>35.56 cm</b>
	COMPRESSED AIR CONNECTION		1/4" Quick Connection	
	COMPRESSED AIR VOLUME		0.75 cfh	<b>0.02 cmh</b>
	BOILER HORSEPOWER (NORMAL LOAD)		11 Bhp	
	SUPPLY CONNECTION		1-1/4" F.N.P.T.	
RETURN CONNECTION		1-1/4" F.N.P.T.		

Shaded areas are stated in metric equivalents

MS 5/26/06

# AD115-ES

**DRYER NOTES:**

- OPERATING HEIGHT OF ELECTRIC DRYER IS 98 [248.91]
- TOP SECTION CAN BE REMOVED FOR EASY INSTALLATION.
- DUCT WORK SIZE VARIES WITH INSTALLATION CONDITIONS
- EXHAUST STATIC PRESSURE MUST BE NO LESS THAN 0 AND MUST NOT EXCEED 0.3" 10.74 mbl WATER COLUMN.
- EXHAUST THIMBLE (14" Ø55.6 cm) IS SHIPPED INSIDE DRYER.

**STEAM DRYER NOTES:**

- SIZE OF PIPING TO DRYER VARIES WITH INSTALLATION CONDITIONS. CONTACT FACTORY FOR ASSISTANCE.
- STEAM DRYERS MUST BE PROVIDED WITH CLEAN, DRY, REGULATED 80 PSI ± 10 PSI (5.5 BAR ± 0.69 BARI) AIR SUPPLY.

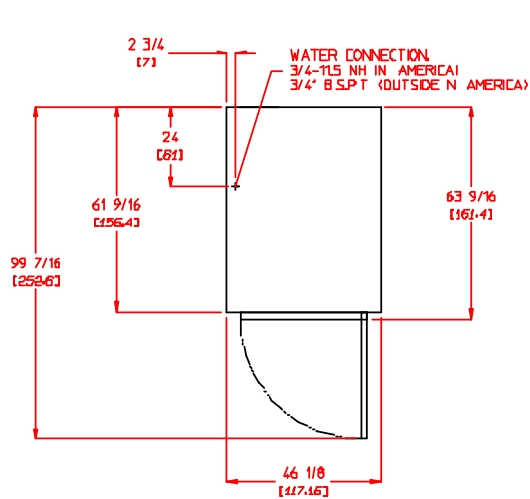

PLAN VIEW

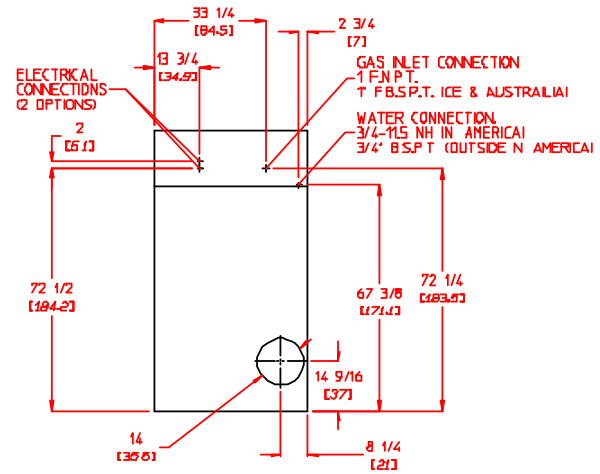

REAR VIEW (GAS AND ELECTRIC)

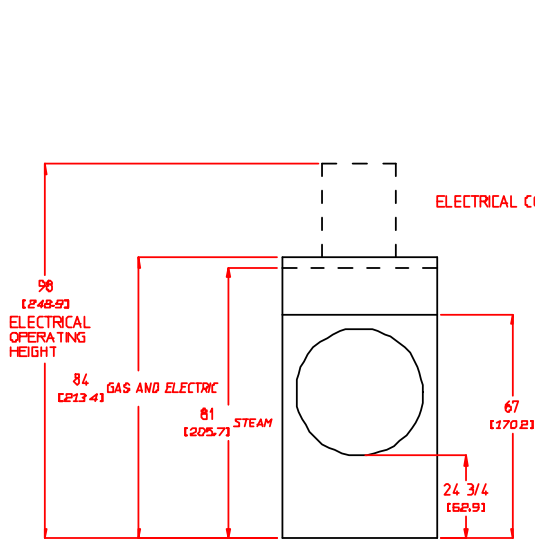

FRONT VIEW

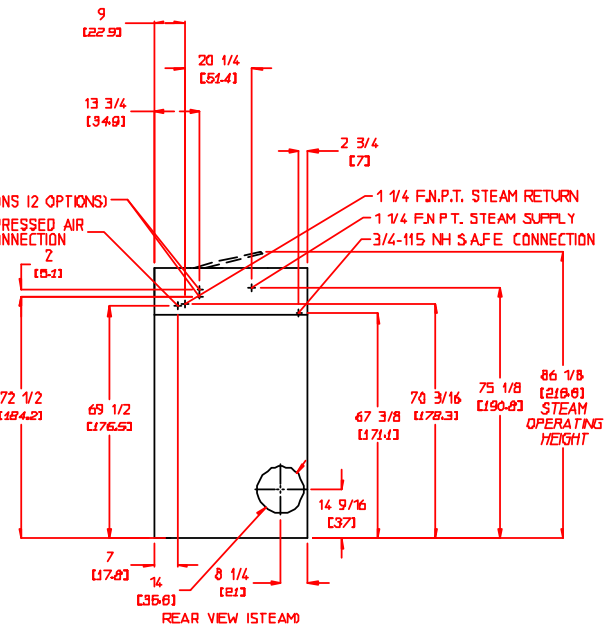

REAR VIEW (STEAM)

NS 6/14/06



88 Currant Road • Fall River, MA 02720  
 Tel. 508-678-9000 • Fax 508-678-9447  
 sales@amdry.com • www.amdry.com