



SL50 SLI-23 M50SL T50

MAXIMUM CAPACITY (DRY WEIGHT)		50 lb	22.68 kg	
TUMBLER DIAMETER		37"	93.98 cm	
TUMBLER DEPTH		25-3/4"	65.41 cm	
TUMBLER VOLUME		16.02 cu ft	453.64 L	
TUMBLER/DRIVE MOTOR		3/4 hp	0.56 kW	
BLOWER/FAN MOTOR		1/2 hp	0.37 kW	
DOOR OPENING (DIAMETER)		27-3/8"	69.53 cm	
DOOR SILL HEIGHT		16"	40.64 cm	
WATER CONNECTION		3/4"-11.5 NH (North America) 3/4" B.S.P.T. (Outside North America)		
DRYERS PER 20'/40' CONTAINER		10 / 22		
DRYERS PER 48'/53' TRUCK		28 / 30		
Gas	VOLTAGE AVAILABLE		120-240V 1ø 2w 50/60 Hz	
	APPROXIMATE NET WEIGHT		545 lb 247.21 kg	
	APPROXIMATE SHIPPING WEIGHT		565 lb 256.28 kg	
	AIRFLOW	60 Hz	525 cfm	14.87 cmm
		50 Hz	437 cfm	12.37 cmm
	HEAT INPUT		90,000 Btu/hr	22,680 kcal/hr
	EXHAUST CONNECTION (DIAMETER)		8"	20.32 cm
	COMPRESSED AIR CONNECTION		N / A	
	COMPRESSED AIR VOLUME		N / A	
	INLET PIPE CONNECTION		1/2" M.N.P.T. 1/2" F.B.S.P.T. (CE and Australia Only)	
Electric	VOLTAGE AVAILABLE		120-600V 1,3ø 2,3,4w 50/60 Hz	
	APPROXIMATE NET WEIGHT		545 lb 247.21 kg	
	APPROXIMATE SHIPPING WEIGHT		565 lb 256.28 kg	
	AIRFLOW	60 Hz	525 cfm	14.87 cmm
		50 Hz	437 cfm	12.37 cmm
	EXHAUST CONNECTION (DIAMETER)		8"	20.32 cm
	COMPRESSED AIR CONNECTION		N / A	
	COMPRESSED AIR VOLUME		N / A	
	OVEN SIZE			
	kW	Btu/hr	kcal/hr	
13.4	45,869	11,559		
14.7	50,136	12,634		
14.8	50,545	12,737		
16.0	54,606	13,761		
Steam	VOLTAGE AVAILABLE		120-240V 1ø 2w 50/60 Hz	
	APPROXIMATE NET WEIGHT		545 lb 247.21 kg	
	APPROXIMATE SHIPPING WEIGHT		565 lb 256.28 kg	
	AIRFLOW	60 Hz	525 cfm	14.87 cmm
		50 Hz	437 cfm	12.37 cmm
	STEAM CONSUMPTION		127.5 lb/hr	57.83 kg/hr
	OPERATING STEAM PRESSURE		150 psi max	10.34 bar
	EXHAUST CONNECTION (DIAMETER)		8"	20.32 cm
	COMPRESSED AIR CONNECTION		N / A	
	COMPRESSED AIR VOLUME		N / A	
	BOILER HORSEPOWER (NORMAL LOAD)		3.75 Bhp	
	SUPPLY CONNECTION		3/4" F.N.P.T.	
RETURN CONNECTION		3/4" M.N.P.T.		

Shaded areas are stated in metric equivalents

Eamon Lyons 4/30/07

SL50

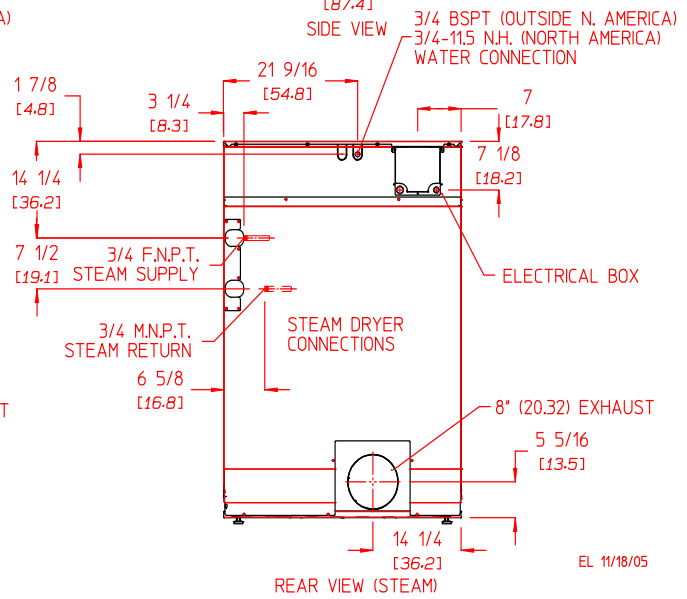
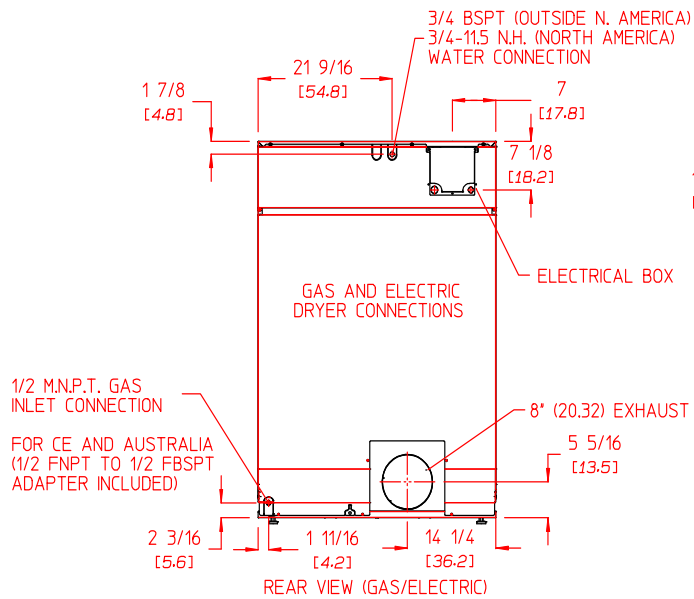
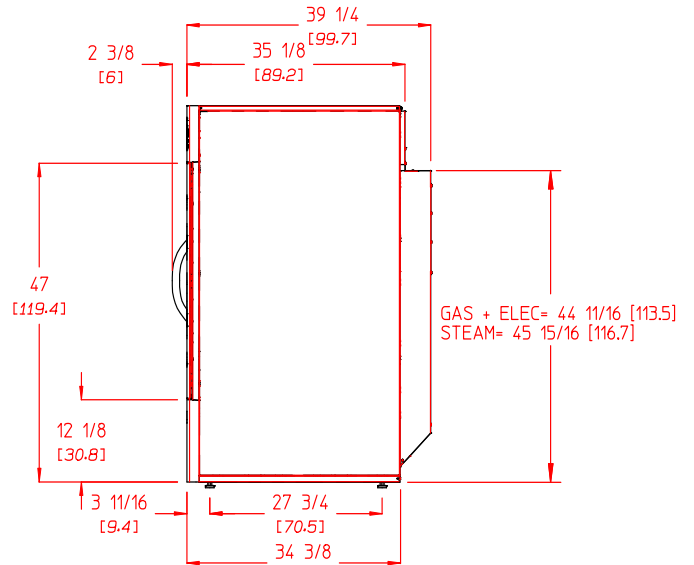
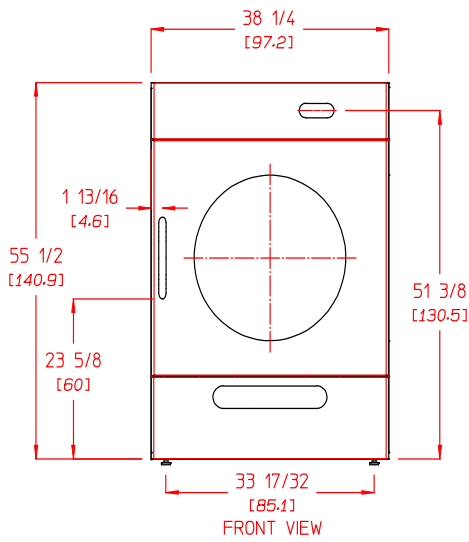

EL 11/18/05



88 Currant Road • Fall River, MA 02720
Tel. 508-678-9000 • Fax 508-678-9447
sales@amdry.com • www.amdry.com